

Technical features

Power supply

Three-phase voltage from 24V to 690V, 50Hz or 60Hz or single-phase 100-130V, 60Hz and 200-240V, 50Hz (single-phase types are supplied without capacitor); suitable for use with an inverter from 20Hz to the base frequency with constant torque load profile.

Polarity

2 or 4 poles.

Conformity with European Directives

Low Voltage 2006/95/EC,
ATEX 94/9/EC.

Reference Regulations

EN 60034-1,
IEC/EN 61241-0, IEC/EN 61241-1

Functioning

Continual service (S1) at maximum declared centrifugal force and electric power. Intermittent services are also possible depending on the type of vibrator and the operating conditions. For detailed information, contact our technical assistance office.

Centrifugal force

Range extended up to 2615 Kgf. (25.7 KN), with centrifugal force adjustable from 0 to 100%.

Mechanical protection

IP 66 according to IEC 529, EN 60529.

Mechanical protection is ensured in the mounting phase of the vibrator onto the vibrating machine, by introducing the special seal into the seat on the coupling flange.

Protection against mechanical impacts
IK 08 according to IEC 68, EN 50102.

Insulation class

Class F (155°C), class H (180°C) on request.

Tropicalization

Standard on all vibrators, with vacuum encapsulation up to size 30, with "drop by drop" trickle system for larger sizes.

Ambient temperature

From -20°C to +40°C. Versions for higher or lower temperatures are available on request.

Vibrator thermal protection

On demand with PTC rated thermistor heat detectors 130°C (DIN 44081-44082). Also on request thermistors with different temperatures and anti-condensation heaters.

Fixing of the vibrator

In all positions and therefore without restriction.

Lubrication

All vibrators are lubricated in the factory and do not require further lubrication if used in normal operating conditions

("FOR LIFE" lubrication). In heavy duty operating conditions periodical re-lubrication may be applied to frame sizes 40-50-70.

Electrical connection box

The size guarantees passage of tools used for fixing the vibrator to the vibrating machine. The electrical connection must be carried out using the relative connectors inserted inside the connection box. Special shaped terminals allow to fix the power supply cable, protecting it from loosening.

Electric motor

Three-phase asynchronous type. Designed for maximum starting torques and torque curves specific to requirements of vibrating machines. Insulated windings through vacuum encapsulating up to size 30; using "drop by drop" trickle system with class H resin for sizes 40-50-70. The rotor is die cast aluminium.

Casing

In high-tensile aluminium alloy up to size 50, in spheroidal cast iron for size 70.

Bearing flange

Constructed in cast iron (spheroidal or grey) or in aluminium with steel bearing seat. The geometry of the flange transmits the load to the casing uniformly.

Bearings

The lower and upper bearings have been studied to support the relative load and therefore they have a particular geometry, especially designed and made for Italvibras.

Motor shaft

In treated steel alloy (Isothermic hardening) resistant to stress.

Eccentric weights

Allow greater adjustment of the centrifugal force, with phase shift of the lower weight assembly with respect to the upper group. This adjustment is eased by a graduated scale, which expresses the centrifugal force as a percentage of the maximum centrifugal force.

Weight covers

In aluminium alloy, mounted only on the lower side. The flange side does not have weight cover. Size 40 is supplied without weights covers on both sides.

Painting

Electrostatic surface treatment based on polymerised epoxy polyester powder in oven at 200°C. Tested in salt spray for 500 hours.

Stainless steel protection

On request, corrosion high grade protection (stainless steel micro suspensions in a polyurethanic paint) is available.

2 poles - 3000/3600 rpm

	Description					Mechanical specifications					Electrical specifications						
	Code	Type	SIZE	IIBD Temp. class	II2D	Centrifugal force (A/B)*				Weight		Max input power		Max. current		I _a /I _n	
						kg	50 Hz	60 Hz	50 Hz	60 Hz	50 Hz	60 Hz	W	50 Hz	60 Hz	A	400 V 50 Hz
three-phase	600375	MTF 3/65-S02	00	-	120°C	31/31	44/44	0.30/0.30	0.43/0.43	5.40	5.40	120	120	0.27	0.23	3.43	3.90
	600369	MTF 3/200-S02	01	•	120°C	106/75	109/109	1.04/0.74	1.07/1.07	7.50	7.30	180	180	0.35	0.30	2.68	3.00
	600370	MTF 3/300-S02	10	•	120°C	151/103	148/148	1.48/1.01	1.45/1.45	11.2	10.9	260	270	0.60	0.50	3.47	4.20
	600378	MTF 3/500-S02	20	•	120°C	251/163	235/235	2.46/1.60	2.30/2.30	15.0	14.1	450	500	0.80	0.75	4.21	4.80
	600456	MTF 3/650-S02	20	•	120°C	393/251	377/235	3.85/2.46	3.70/2.30	15.2	14.3	450	500	0.80	0.75	4.21	4.80
	600380	MTF 3/800-S02	30	•	120°C	393/262	377/377	3.85/2.57	3.70/3.70	17.0	16.5	650	685	1.10	1.00	3.83	6.00
	600285	MTF 3/1100-S90 Δ	40	-	120°C	590/590	566/566	5.79/5.79	5.55/5.55	26.0	25.0	940	1130	1.70	1.60	6.79	7.00
single-phase	600375	MTF 3/65-S02	00	-	120°C	31/31	44/44	0.30/0.30	0.43/0.43	5.40	5.40	110	110	0.56	1.52	2.24	2.24
	600369	MTF 3/200-S02	01	-	120°C	106/75	109/109	1.04/0.74	1.07/1.07	7.50	7.30	165	165	0.75	1.52	1.67	2.24
	600370	MTF 3/300-S02	10	-	120°C	151/103	148/148	1.48/1.01	1.45/1.45	11.2	10.9	280	280	1.25	2.40	2.48	3.52
	600378	MTF 3/500-S02	20	-	120°C	251/163	235/235	2.46/1.60	2.30/2.30	15.0	14.1	500	500	2.30	4.50	3.35	4.22
	600456	MTF 3/650-S02	20	-	120°C	393/251	377/235	3.85/2.46	3.70/2.30	15.2	14.3	500	500	2.30	4.50	3.35	4.22
	600380	MTF 3/800-S02	30	-	120°C	393/262	377/377	3.70/2.57	5.55/5.55	17.0	16.5	700	750	3.25	7.00	4.00	4.14

* Listed as A/B: total centrifugal force is the sum of centrifugal force of top weights (A) and centrifugal force of bottom weights (B). I_a/I_n = ratio between start-up current and maximum current.
 Δ Supplied without weight covers on both sides.

2 poles - 3000/3600 rpm

	Type	Dimensional specifications (mm)															Capacitor (µF)		Cable entry thread	Seal g
		Fig.	A	øB	øC	Holes			E	F	G	I	L	M	øP	220 V	115 V			
						øD	øH	N°								50 Hz	60 Hz			
three-phase	MTF 3/65-S02	G	189	130	86	109	8.5	4	132	7.5	10	36	96	22	-	-	-	M20x1,5	OR 3350	
	MTF 3/200-S02	G	225.5	211.5	92	188	12	4	144	21 (50Hz) 15 (60Hz)	10	58	103	23.5	-	-	-	M20x1,5	OR 4650	
	MTF 3/300-S02	G	247	215	110	187	12	4	179.5	18 (50Hz) 12 (60Hz)	13	54	127	13.5	-	-	-	M20x1,5	OR 4625	
	MTF 3/500-S02	G	279.5	245	122	205	12	6	124	24 (50Hz) 15 (60Hz)	12	65	145	90.5	162	-	-	M25x1,5	OR 4700	
	MTF 3/650-S02	G	279.5	245	150 (50Hz) 132 (60Hz)	205	12	6	124	18	12	65	145	90.5	162	-	-	M25x1,5	OR 4700	
	MTF 3/800-S02	G	301	260	150 (50Hz) 132 (60Hz)	230	15	6	182	18	15	63	170	56	150	-	-	M25x1,5	OR 4800	
	MTF 3/1100-S90 Δ	G	383	279	145	254	14	4	-	31 (50Hz) 21 (60Hz)	17.5	57.5	-	63	229	-	-	M25x1,5	-	
single-phase	MTF 3/65-S02	G	189	130	86	109	8.5	4	132	7.5	10	36	96	22	-	10	28	M20x1,5	OR 3350	
	MTF 3/200-S02	G	225.5	211.5	92	188	12	4	144	21 (50Hz) 15 (60Hz)	10	58	103	23.5	-	10	28	M20x1,5	OR 4650	
	MTF 3/300-S02	G	247	215	110	187	12	4	179.5	18 (50Hz) 12 (60Hz)	13	54	127	13.5	-	16	25	M20x1,5	OR 4625	
	MTF 3/500-S02	G	279.5	245	122	205	12	6	124	24 (50Hz) 15 (60Hz)	12	65	145	90.5	162	12.5	50	M25x1,5	OR 4700	
	MTF 3/650-S02	G	279.5	245	150 (50Hz) 132 (60Hz)	205	12	6	124	18	12	65	145	90.5	162	12.5	50	M25x1,5	OR 4700	
	MTF 3/800-S02	G	301	260	150 (50Hz) 132 (60Hz)	230	15	6	182	18	15	63	170	56	150	25	90	M25x1,5	OR 4800	

Δ Supplied without weight covers on both sides

Fig. G

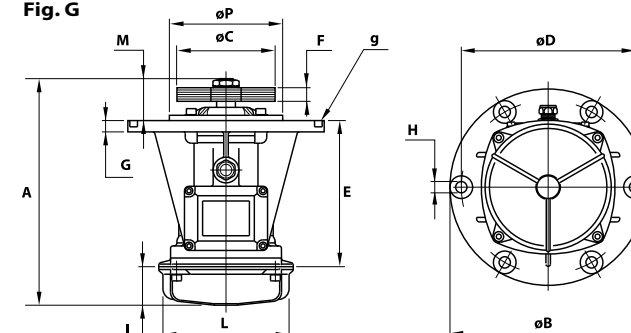

4 poles - 1500/1800 rpm

Description		Mechanical specifications								Electrical specifications							
		Code	Type	SIZE	IICZ Temp. class	Centrifugal force (A/B)*				Weight		Max input power		Max. current		I _m /I _n	
						kg	60 Hz	50 Hz	60 Hz	50 Hz	60 Hz	50 Hz	60 Hz	400 V 50 Hz	460 V 60 Hz	50 Hz	60 Hz
three-phase	601446	MTF 15/80-S02	01	• 120°C	39/39	38/38	0.38/0.38	0.37/0.37	6.8	6.5	85	95	0.21	0.20	1.78	1.95	
	601403	MTF 15/200-S02	10	• 120°C	106/74	107/107	1.04/0.72	1.05/1.05	14.0	13.2	170	170	0.41	0.40	2.34	2.75	
	601405	MTF 15/400-S02	20	• 120°C	205/142	205/205	2.01/1.39	2.01/2.01	20.6	19.8	300	350	0.60	0.60	3.33	3.50	
	601406	MTF 15/550-S02	20	• 120°C	276/205	295/295	2.70/2.01	2.70/2.70	22.0	20.6	300	350	0.60	0.60	3.33	3.50	
	601407	MTF 15/700-S02	30	• 120°C	360/263	380/380	3.53/2.58	3.73/3.73	26.0	24.5	525	665	0.92	0.98	3.48	3.43	
	601280	MTF 15/1100-S90 Δ	40	- 120°C	522/522	491/491	5.12/5.12	4.82/4.82	36.0	31.4	900	1050	1.45	1.50	4.10	4.20	
	601379	MTF 15/1710-S02-VRS	50	- 150°C	894/322	878/355	8.77/3.16	8.61/3.48	44.0	41.5	1100	1200	2.00	1.90	4.29	4.89	
	601380	MTF 15/2000-S02-VRS	50	- 170°C	1021/357	1017/390	10.0/3.50	9.98/3.83	48.0	45.5	1350	1450	2.50	2.30	4.30	4.90	
	601381	MTF 15/3810-S02-VRS	70	- 135°C	1908/707	1872/718	18.7/6.94	18.4/7.04	100	93	2200	2500	3.90	3.90	7.11	6.92	
single-phase	601446	MTF 15/80-S02	01	- 120°C	39/39	38/38	0.38/0.38	0.37/0.37	6.8	6.5	90	100	0.43	1.00	1.20	1.30	
	601403	MTF 15/200-S02	10	- 120°C	106/74	107/107	1.04/0.72	1.05/1.05	14.0	13.2	210	230	1.00	2.00	1.50	1.85	
	601405	MTF 15/400-S02	20	- 120°C	205/142	205/205	2.01/1.39	2.01/2.01	20.6	19.8	240	320	1.20	2.80	2.50	2.50	
	601406	MTF 15/550-S02	20	- 120°C	276/205	295/295	2.70/2.01	2.70/2.70	22.0	20.6	240	320	1.20	2.80	2.50	2.50	
	601407	MTF 15/700-S02	30	- 120°C	360/263	380/380	3.53/2.58	3.73/3.73	26.0	24.5	450	550	2.15	5.15	5.44	3.63	

* Listed as A/B: total centrifugal force is the sum of centrifugal force of top weights (A) and centrifugal force of bottom weights (B). I_m/I_n = ratio between start-up current and maximum current.
 Δ Supplied without weight covers on both sides.

4 poles - 1500/1800 rpm

	Type	Dimensional specifications (mm)														Capacitor (µF)		Cable entry thread	Seal g
		Fig.	A	øB	øC	Holes			E	F	G	I	L	M	øP	220 V 50 Hz	115 V 60 Hz		
three-phase	MTF 15/80-S02	G	225.5	211.5	92	188	12	4	144	31 (50Hz) 21 (60Hz)	10	58	103	23.5	-	-	-	M20x1,5	OR 4650
	MTF 15/200-S02	G	292.5	215	114 (50Hz) 108 (60Hz)	187	12	4	179.5	48 (50Hz) 40 (60Hz)	13	77	127	36	-	-	-	M20x1,5	OR 4625
	MTF 15/400-S02	G	335.5	245	130	205	12	6	124	59 (50Hz) 42 (60Hz)	12	93	145	118.5	162	-	-	M25x1,5	OR 4700
	MTF 15/550-S02	G	376.5	245	130	205	12	6	124	79 (50Hz) 59 (60Hz)	12	114	145	138.5	162	-	-	M25x1,5	OR 4700
	MTF 15/700-S02	G	380.5	260	154	230	15	6	182	59 (50Hz) 46 (60Hz)	15	106	170	92.5	150	-	-	M25x1,5	OR 4800
	MTF 15/1100-S90 Δ	G	426	279	190	254	14	4	-	49	17.5	57.5	-	84.5	229	-	-	M25x1,5	-
	MTF 15/1710-S02-VRS	G	488	350	190	290	17	6	232	84 (50Hz) 58 (60Hz)	18	134	209	122	172	-	-	M25x1,5	-
	MTF 15/2000-S02-VRS	G	561	350	190	290	17	6	232	96 (50Hz) 66 (60Hz)	18	171	209	158	172	-	-	M25x1,5	-
	MTF 15/3810-S02-VRS	G	614	410	250 (50Hz) 244 (60Hz)	350	22	6	310	78 (50Hz) 58 (60Hz)	20	178	280	125.5	234	-	-	M25x1,5	-
single-phase	MTF 15/80-S02	G	225.5	211.5	92	188	12	4	144	31 (50Hz) 21 (60Hz)	10	58	103	23.5	-	3.15	25	M20x1,5	OR 4650
	MTF 15/200-S02	G	292.5	215	114 (50Hz) 108 (60Hz)	187	12	4	179.5	48 (50Hz) 40 (60Hz)	13	77	127	36	-	5	25	M20x1,5	OR 4625
	MTF 15/400-S02	G	335.5	245	130	205	12	6	130	59 (50Hz) 42 (60Hz)	12	93	145	118.5	162	32/12 ○	35	M20x1,5	OR 4700
	MTF 15/550-S02	G	376.5	245	130	205	12	6	130	79 (50Hz) 59 (60Hz)	12	114	145	138.5	162	32/12 ○	40/35 ○	M20x1,5	OR 4700
	MTF 15/700-S02	G	380.5	260	154	230	15	6	182	59 (50Hz) 46 (60Hz)	15	106	170	92.5	150	96/16 ○	160/40 ○	M25x1,5	OR 4800

Δ Supplied without weight covers on both sides ○ Start-up capacitor / Running capacitor.

